

DATE CODE  
 DETAIL A  
 (SCALE=5/1)  
 FEMALE  
 SCREW  
 M2x0.4

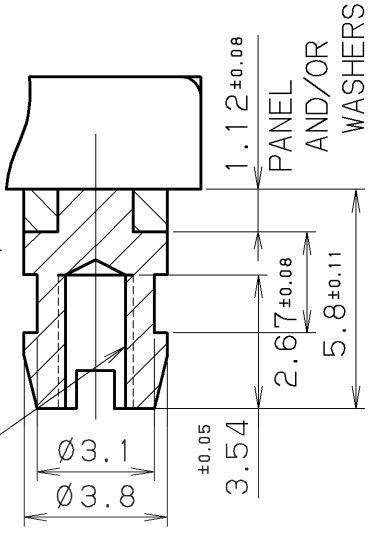

NOTE #2.  
 FOUR LOCK SCREWS (ITEM#6)  
 ARE SUPPLIED WITH CONNECTOR.

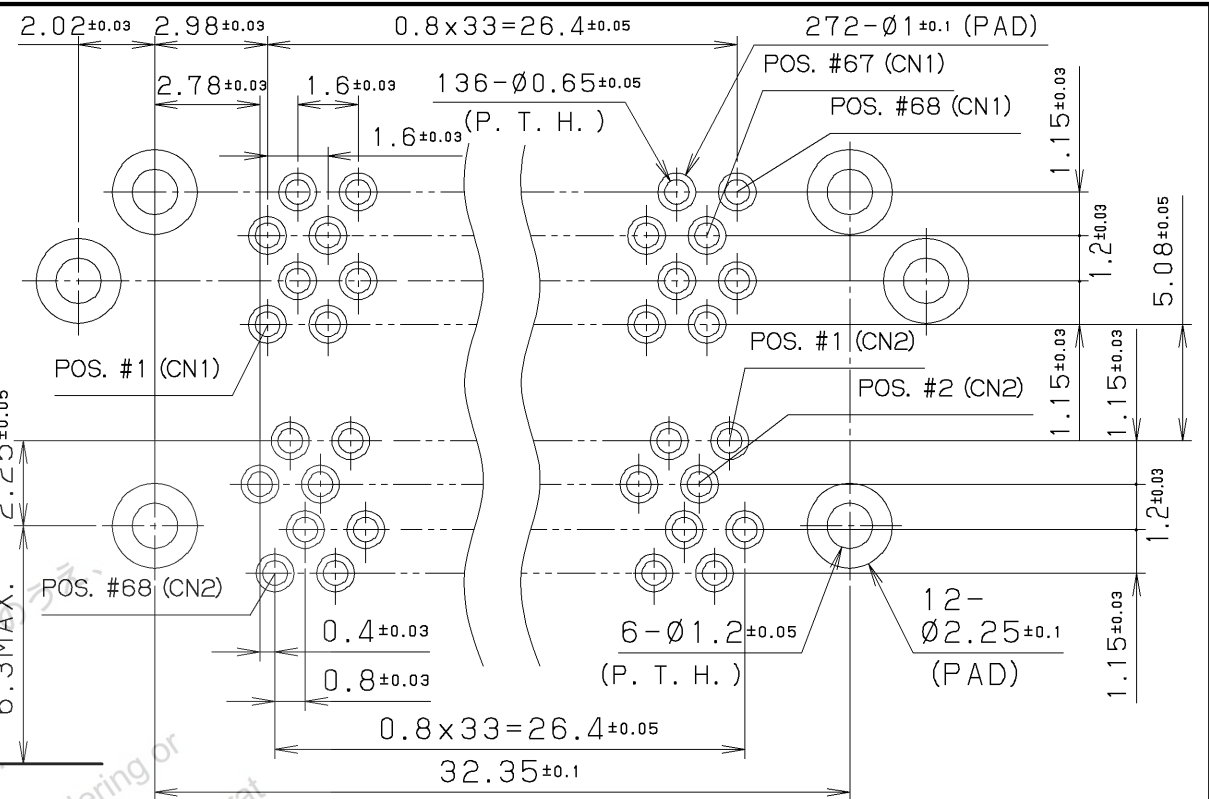

RECOMMENDED P.C.B. LAYOUT t=1.6±0.1 (SCALE=5/1)  
 (MOUNT SIDE VIEW)

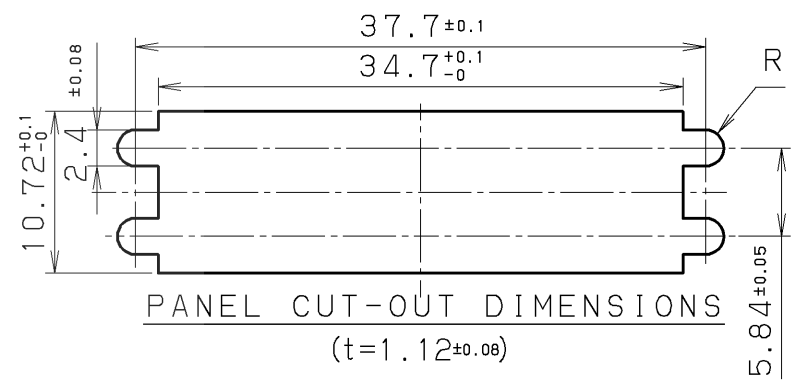
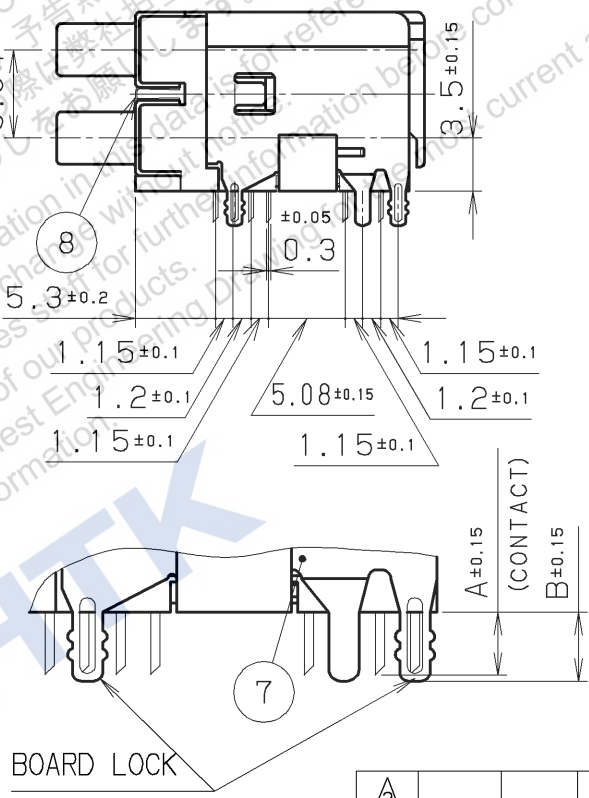
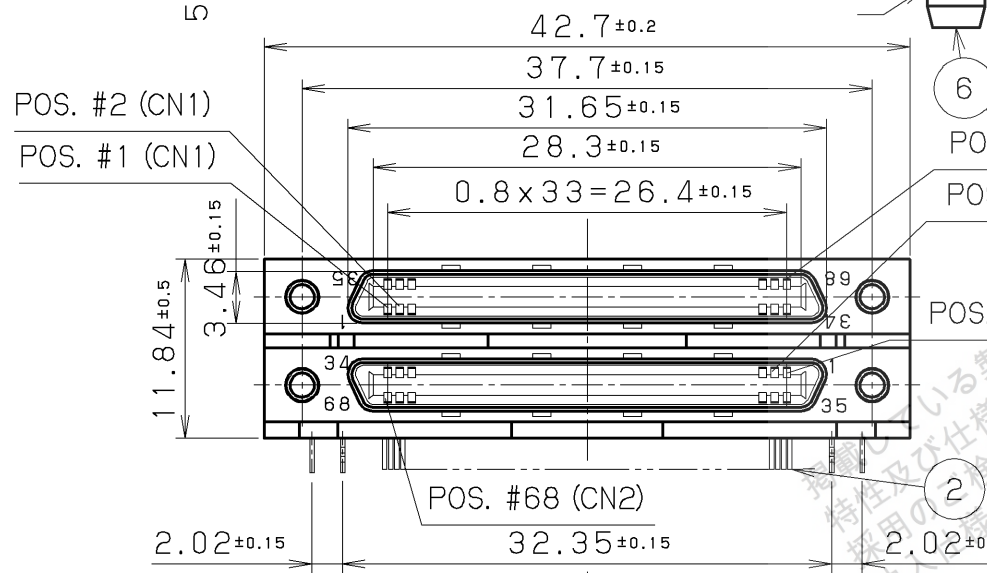

NOTE #1.  
 CONTACT PLATING

CONTACT AREA: GOLD 0.1 μm MIN.  
 OVER PALLADIUM/NICKEL 0.5 μm

TERMINAL AREA: GOLD 0.05 μm  
 ALL OVER NICKEL UNDERPLATED.

HDRA-E68W5LFDT1EC-SL+	2.72	3.6	BLACK
HDRA-E68W2LFDT1EC-SL+	3.4	3.6	BROWN
HDRA-E68W1LFDT1EC-SL+	2.08	2.28	BLACK
PART No.	A	B	COLOR OF BRACKET

9	PROTECTIVE COVER	PPS	1		UL94V-0 BLACK
8	SPACER	STEEL	1		
7	BOARD LOCK	PHOSPHOR BRONZE	2	NICKEL PLATING	
6	LOCK SCREW	STEEL	4	NICKEL PLATING	M2x0.4 SEE NOTE #2
5	SQR. NUT	BRASS	4	NICKEL PLATING	M2x0.4
4	SHELL	STEEL	2	NICKEL PLATING	
3	INSULATOR	PPS	1		UL94V-0 BLACK
2	CONTACT	PHOSPHOR BRONZE	136	SEE NOTE #1	
1	BRACKET	PPS	1		UL94V-0

△										
△										
△	Mar. 16 2021	S. M	Add DATE CODE							
LTR.	DATE	BY	REV.	DESCRIPT	No.	PART NAME	MATERIAL	QTY	FINISH	NOTE
	DATE		SCALE		UNIT	3RD. A. P	<b>HTK</b> HONDA TSUSHIN KOGYO CO., LTD.			
	Dec. 16, 2004		2 / 1		mm (INCH)		NAME 0.8mm SPACING 68POS. R/A DUAL STACKING FEMALE CONNECTOR			
	APP. DATE & REV.						PART NO. HDRA-E68W ( ) LFDT1EC-SL+ REV. 1A			
	DR.	DE.	CHK.	CHK.	APP.					
	S. MURAKAMI	S. MURAKAMI	S. YOSHIDA	—	K. OOKU					