

Note 1) This drawing shows assembled.
However, Parts are shipped unassembled.

Table 1)

Part No.	Coupling Device Color	Boot Color
LGC-PH353MK+R	Blue	Blue
LGC-PH353MKL+R	Blue	Mauve
LGC-PH353MKW+R	Blue	White
LGC-PH353MKGR+R	Green	Green

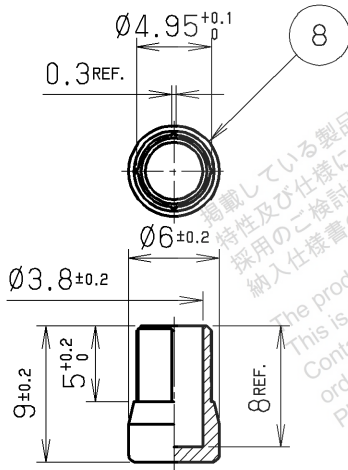

RoHS COMPLIANT

③				8	Cap	Polyester elastomer	1	————	Color:Blue
②				7	Boot	Polyester elastomer	1	————	See Table 1
①				6	Ring	Brass	1	Nickel Plated	————
				5	Clamping Ring	Aluminium Alloy	1	————	————
				4	Stop-ring	PBT Resin	1	————	Color:Black
				3	Spring	Stainless Steel	1	————	————
				2	Plug-frame	PBT Resin	1	————	Color:White
				1	Coupling Device	PBT Resin	1	————	See Table 1

LTR.	DATE	BY	REV.	DESCRIPT	No.	PART NAME	MATERIAL	QTY	FINISH	NOTE
	DATE		SCALE		UNIT	3RD. A. P	HONDA TSUSHIN KOGYO CO., LTD.			
	Oct.11.2007		2/1		mm (INCH)					
	APP. DATE&REV.									
	DR.	DE.	CHK.	CHK.	APP.	NAME	SC-PH Type Connector Plug Housing (RoHS)			
	T. KOISO	—	Y. OHKUBO	—	T. EGUCHI	PART NO.	LGC-PH353MK () +R			