

Abbreviation of the item name.  
Abbreviation of the corporation name. (opposite side)

Note 1) This drawing shows assembled product.  
However, All parts are shipped unassembled.

Note 2) A cap is assembled to this part.

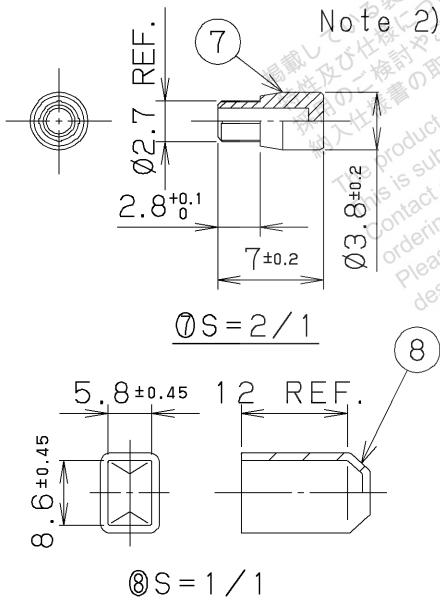

Table 1

Part No.	Boot color	Cap
LGC-2PH604	Mauve	①
LGC-2PH604B	Blue	②
LGC-2PH604BP	Blue	③

8	Cap	PVC Resin	1	---	Color:Black
7	Cap	Polyester elastomer	2	---	Color:Blue
6	Boot	Polyester elastomer	2	---	See Table 1
5	Clamping Ring	Brass	2	Nickel plated	---
4	Stop-ring	Brass	2	Nickel plated	---
3	Spring	Piano wire	2	Nickel plated	②
2	Plug-frame	PBT Resin	2	---	Color:White
1	Coupling Device	PBT Resin	1	---	Color:Brown

③					
②	OCT. 25 2004	N. G	Plating change		
①	FEB. 17. 2004	K. T	Add a postscript		
LTR.	DATE	BY	REV.	DESCRIPT	No.
					PART NAME
					MATERIAL
					QTY
					FINISH
					NOTE

DATE		SCALE		UNIT		3RD. A. P		HONDA TSUSHIN KOGYO CO., LTD.	
SEP. 11. 2003		2/1		mm (INCH)					
APP. DATE & REV.								NAME	
								MU-2PH Type Connector Plug Housing (For Ø2 Cord) ①	
DR.		DE.		CHK.		CHK.		APP.	
N. GOTO		---		T. YOSHIZAKI		K. TOMOYASU		T. EGUCHI	
PART NO.		LGC-2PH604 ( )		REV.		2B			