

SECTION AA' (20/1)

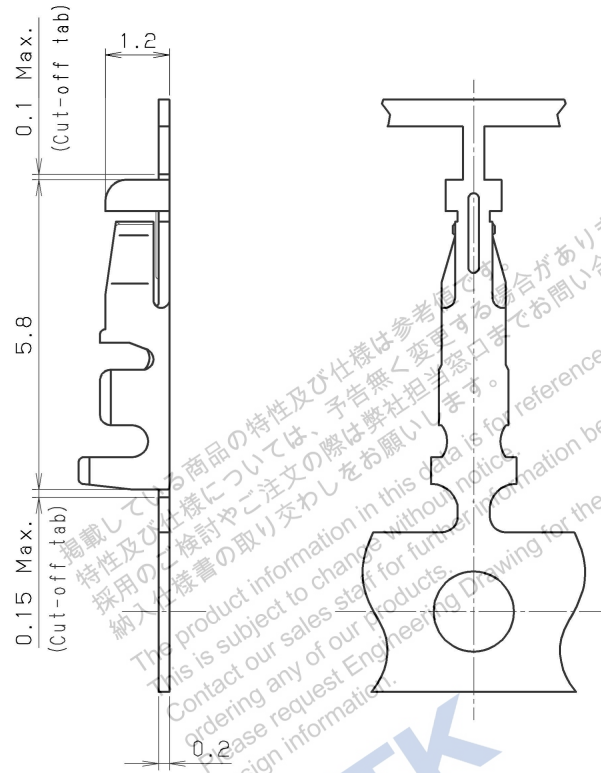

SECTION BB' (20/1)

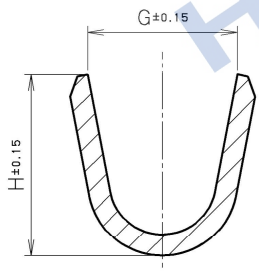
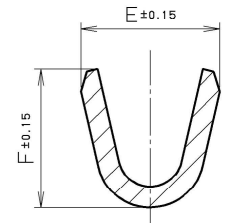

TABLE 1

| PART NO.     | PLATING  |                      |
|--------------|--|----------------------|
|              | CONTACT AREA                                   | OTHERWISE            |
| LPC-F103 ( ) | GOLD 0.2 $\mu$ m min OVER NICKEL 1 $\mu$ m min | NICKEL 1 $\mu$ m min |
| LPC-F104 ( ) | TIN 0.8 $\mu$ m min OVER COPPER 1 $\mu$ m min  |                      |

TABLE 2

| PART NO.      | COMPATIBLE WIRE |                       |
|---------------|-----------------|-----------------------|
|               | CORE WIRE       | INSULATION DIA. RANGE |
| LPC-F10 ( ) S | AWG#32          | 0.6                   |
| LPC-F10 ( ) N | AWG#28~32       | 0.7~1.0               |
| LPC-F10 ( ) L | AWG#22~26       | 0.9~1.1               |

TABLE 3

| PART NO.      | E   | F   | G   | H   |
|---------------|-----|-----|-----|-----|
| LPC-F10 ( ) S | 1.3 | 1.3 | 1.4 | 1.3 |
| LPC-F10 ( ) N | 1.3 | 1.3 | 1.4 | 1.7 |
| LPC-F10 ( ) L | 1.8 | 1.8 | 1.5 | 2.1 |

NOTE1. AS FOR THE SPEC, SEE TABLE #2, #3.

2. CONTINUOUS TERMINAL FOR AUTOMATIC CRIMPING MACHINE.  
(10000PCS/REEL)

| LTR.     | DATE           | BY       | REV. DESCRIPT | No.     | PART NAME   | MATERIAL        | QTY   | FINISH       | NOTE |
|----------|----------------|----------|---------------|---------|---|-----------------|-------|--------------|------|
|          |                |          |               |         |   |                 |       |              |      |
|          |                |          |               |         |   |                 |       |              |      |
|          | MAY.23.2015    | S. IJIMA | REVISE        |         | CONTACT   | PHOSPHOR BRONZE | 10000 | SEE TABLE #1 | ---  |
|          | DATE           |          | SCALE         |         | UNIT  |                 |       |              |      |
|          | APR.30 (1997)  |          | 10/1          |         | mm (INCH)   |                 |       |              |      |
|          | APP. DATE&REV. |          |               |         | 3RD. A. P   |                 |       |              |      |
| DR.      | DE.            | CHK.     | CHK.          | APP.    | <b>HTK</b> HONDA TSUSHIN KOGYO CO., LTD.<br>NAME: FEMALE CONTACT<br>PART NO.: LPC-F10 ( ) ( ) |                 |       |              |      |
| S. IJIMA | S. IJIMA       | ---      | ---           | Y. KATO |   |                 |       |              |      |